

## Distribution Box DB-SS



### DESCRIPTION / APPLICATION

The DB-SS series distribution box is designed for samite range, can be equipped with various modular electrics for the function of terminal power distribution. It is widely used in low voltage distribution networks for power supplying of consumers and commercial buildings.

### MAIN TECHNICAL DATA

<b>Standard</b>	IEC60439-3
<b>Protection Degree</b>	IP40
<b>Mounting Type</b>	Surface & Flush
<b>Storage Temperature</b>	-40°C ~75°C
<b>Ambient Temperature</b>	-5°C ~40°C Max 95% humidity
<b>Material</b>	ABS or PS (optional)/ Steel
<b>Rail</b>	35mm din rail / mini rail

## DIMENSIONS AND MOUNTING

Item code	Size (mm)			Terminal arrangement
	L	W	H	
DB-SS-10W-PS	184	200	100	5+5+3
DB-SS-16W-PS	256	200	100	6+6+4
DB-SS-10W-PF	179	200	85	5+5+3
DB-SS-16W-PF	258	200	85	6+6+4
DB-SS-10W-PSF	180	185	85	5+5+3
DB-SS-16W-PSF	250	185	85	6+6+4

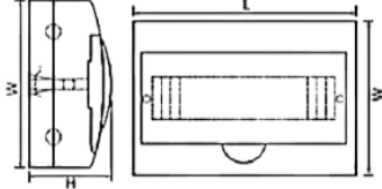

**Surface Mounted**

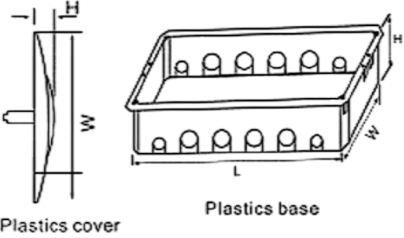

**Flush Mounted**

## PART NUMBER EXAMPLE

BASE NUMBER	WAY	MATERIAL	Mounting way
DB-SS	10	P=Plastic PS=Plastic+steel	Surface/Flush
<b>EXAMPLE</b>	<b>DB-SS-10W-PF (DB PVC FLUSH SAMITE 10WAY)</b>		
	<b>DB-SS-10W-PSF (DB PVC FLUSH SAMITE STEEL TRAY 10WAY)</b>		