

Fuse Switch Disconnect



DNH1-160
 DNH1-250
 DNH1-400
 DNH1-630

CE IEC 60947-3
 IEC 60269-2

Model & Meaning

E.g : DNH3-630/30

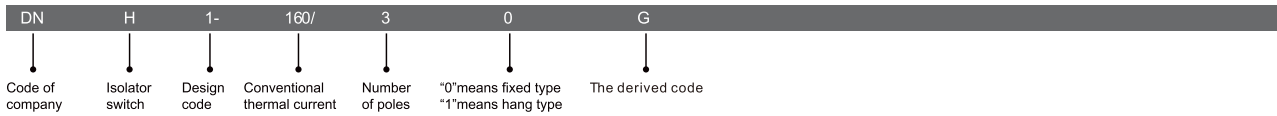

Installation type

Installation mode

Installation mode

Fixed type

Hang type

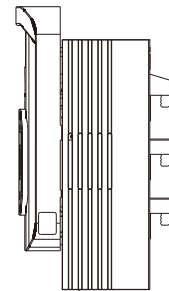
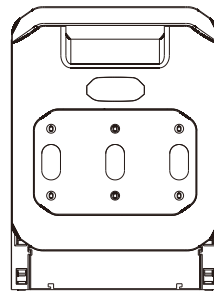
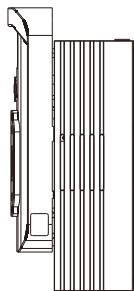
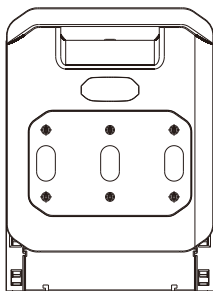
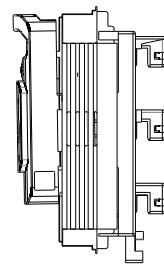
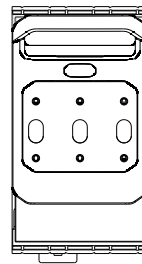
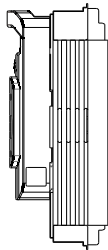
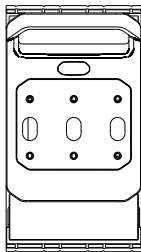

Technical Parameter

Electrical parameter				DNH1-630			DNH1-400			DNH1-250			DNH1-160		
				AC400	AC690	DC440	AC400	AC690	DC440	AC400	AC690	DC440	AC400	AC690	DC440
Technical Parameter	Rated working voltage	Ue	V	AC400	AC690	DC440	AC400	AC690	DC440	AC400	AC690	DC440	AC400	AC690	DC440
	Rated working current	Ie	A	630	425	630	400	315	400	250	200	250	160	100	160
	Conventional thermal current	Ith	A	630	425	630	400	315	400	250	200	250	160	100	160
	Rated limited short-circuit current (with fuse link)		KA	100	50	100	100	50	100	100	50	100	100	50	100
	Utilization Category (with fuse link)			AC-23B	AC-21B	DC-21B	AC-23B	AC-21B	DC-21B	AC-23B	AC-21B	DC-21B	AC-23B	AC-21B	DC-21B
	Rated insulation voltage	Ui	V	1000	1000	1000	1000	1000	1000	1000	1000	1000	1000	1000	1000
	Rated surge-resistant voltage	Uimp	KV	12	12	12	12	12	12	12	12	12	12	12	12
	Rated frequency		Hz	50/60	50/60	50/60	50/60	50/60	50/60	50/60	50/60	50/60	50/60	50/60	50/60
	Electrical durability times		times	200	200	200	200	200	200	200	200	200	200	200	200
	Maximum torque		N.m	28	28	28	20	20	20	20	20	20	12	12	12
Fuse	Size : IEC60269-2			3	3	3	2	2	2	1	1	1	00	00	00
	Rated working current	In	A	630	425	630	400	315	400	250	200	250	160	100	160
	Loss power	Pn	W	48	60	48	34	45	34	23	32	23	12	12	12

Installation dimension

Fixed type configuration & installation dimension

DNH1-160/30

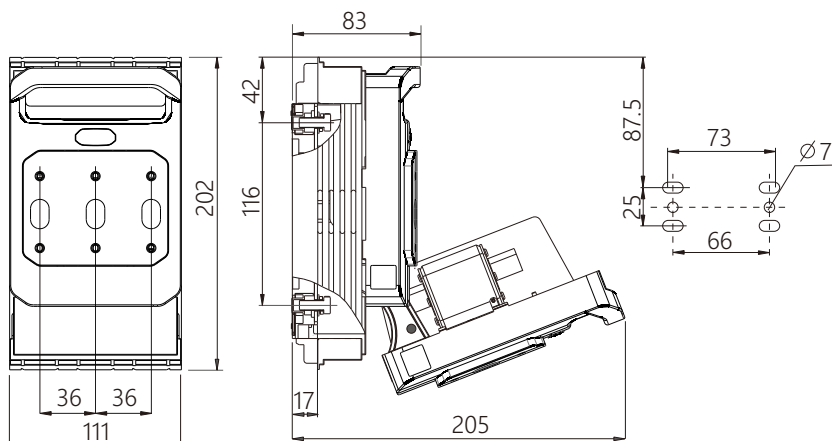

Hook type configuration & installation dimensions

DNH1-160/31

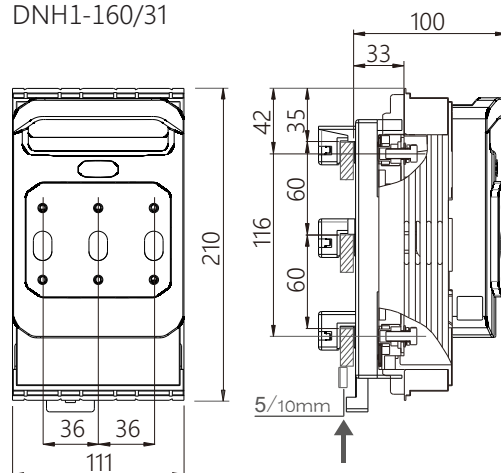

DNH1-250
DNH1-400
DNH1-630

DNH1-250
DNH1-400
DNH1-630

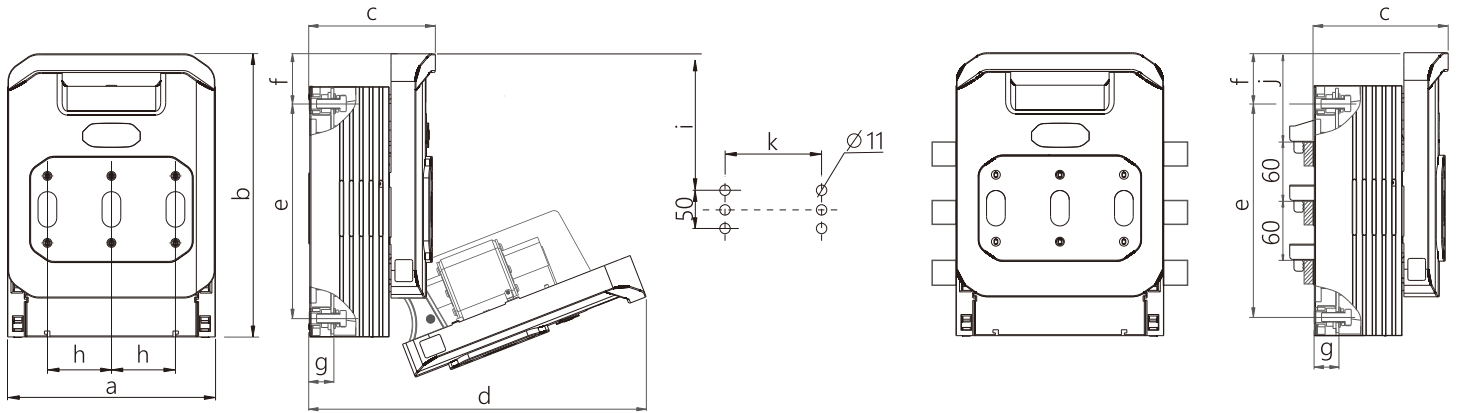

Specification table

model	a	b	c	d	e	f	g	h	i	j	k
DNH1-250/30	185	247	111	295	185	42.5	22.5	57	110	/	114
DNH1-250/31	185	247	121	305	185	42.5	32.5	57	/	67.5	/
DNH1-400/30	210	288	129	344	210	52	26	65	132	/	130
DNH1-400/31	210	288	137	353	210	52	34.5	65	/	90	/
DNH1-630/30	256	304	146	361	211	54	30	81	135	/	162
DNH1-630/31	256	304	155	370	211	54	39	81	/	90	/

Fuse (with 1 indicator)

Item No.	Rated Current In	Rated Voltage Un	Breaking Capacity (with Fuse)	Overall Dimensions mm						
				A	B	C	D	E	F	G
NH00	In:2A, 4A, 6A, 8A, 10A, 12A, 16A, 20A, 25A, 32A, 40A, 50A, 63A, 80A, 100A, 125A, 160A(500VAC/440VDC); In:2A, 4A, 6A, 8A, 10A, 12A, 16A, 20A, 25A, 32A, 40A, 50A, 63A, 80A, 100A(690VAC)	500VAC	120kA(500VAC)	78±0.5	50	29	6	47	58	15
		690VAC 250VDC	50kA(690VAC) 100kA(250VDC)							
NH1	In:40A, 50A, 63A, 80A, 100A, 125A, 160A, 200A, 225A, 250A (500VAC/440VDC); In:40A, 50A, 63A, 80A, 100A, 125A, 160A, 200A(690VAC)	500VAC	120kA(500VAC)	134±0.5	66	46	6	46	60	20
		690VAC	50kA(690VAC)							
		440VDC	100kA(440VDC)							
NH2	In:80A, 100A, 125A, 160A, 200A, 250A, 315A, 350A, 400A(500VAC/440VDC); In: 80A, 100A, 125A, 160A, 200A, 250A, 315A (690VAC)	500VAC	120kA(500VAC)	150±0.5	66	59	6	59	72	25
		690VAC	50kA(690VAC)							
		440VDC	100kA(440VDC)							
NH3	In: 315A, 400A, 500A, 630A (500VAC/440VDC); In: 315A, 400A, 500A(690VAC)	500VAC	120kA(500VAC)	150±0.5	66	68	6	68	83	32
		690VAC	50kA(690VAC)							
		440VDC	100kA(440VDC)							

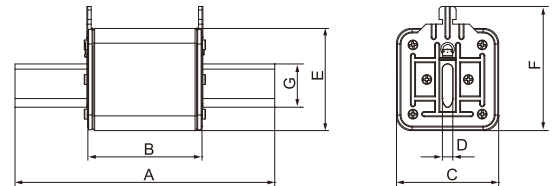

Fuse (with double indicator)

Item No.	Rated Current In	Rated Voltage Un	Breaking Capacity (with Fuse)	Overall Dimensions mm						
				A	B	C	D	E	F	G
NH00	In:2A, 4A, 6A, 8A, 10A, 12A, 16A, 20A, 25A, 32A, 40A, 50A, 63A, 80A, 100A, 125A, 160A(500VAC/440VDC);	500VAC 690VAC 250VDC	120kA(500VAC) 50kA(690VAC) 100kA(250VDC)	78±0.5	50	29	6	47	58	15
	In:2A, 4A, 6A, 8A, 10A, 12A, 16A, 20A, 25A, 32A, 40A, 50A, 63A, 80A, 100A(690VAC)									
NH1	In:40A, 50A, 63A, 80A, 100A, 125A, 160A, 200A, 225A, 250A (500VAC/440VDC);	500VAC 690VAC 440VDC	120kA(500VAC) 50kA(690VAC) 100kA(440VDC)	134±0.5	66	46	6	46	60	20
	In:40A, 50A, 63A, 80A, 100A, 125A, 160A, 200A(690VAC)									
NH2	In:80A, 100A, 125A, 160A, 200A, 250A, 315A, 350A, 400A(500VAC/440VDC);	500VAC 690VAC 440VDC	120kA(500VAC) 50kA(690VAC) 100kA(440VDC)	150±0.5	66	59	6	59	72	25
	In: 80A, 100A, 125A, 160A, 200A, 250A, 315A (690VAC)									
NH3	In: 315A, 400A, 500A, 630A (500VAC/440VDC);	500VAC 690VAC 440VDC	120kA(500VAC) 50kA(690VAC) 100kA(440VDC)	150±0.5	66	68	6	68	83	32
	In: 315A, 400A, 500A(690VAC)									

