

## 2SA1015LT1 TRANSISTOR (PNP)

### FEATURES

Power dissipation

$$P_{CM}: 0.2 \text{ W (Tamb=25°C)}$$

Collector current

$$I_{CM}: -0.15 \text{ A}$$

Collector-base voltage

$$V_{(BR)CBO}: -50 \text{ V}$$

Operating and storage junction temperature range

$$T_J, T_{stg}: -55°C \text{ to } +150°C$$

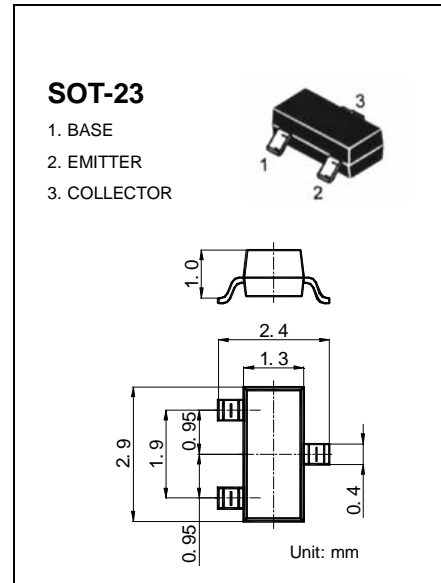

### ELECTRICAL CHARACTERISTICS (Tamb=25°C unless otherwise specified)

Parameter	Symbol	Test conditions	MIN	TYP	MAX	UNIT
Collector-base breakdown voltage	$V_{(BR)CBO}$	$I_C = -100\mu A, I_E = 0$	-50			V
Collector-emitter breakdown voltage	$V_{(BR)CEO}$	$I_C = -0.1mA, I_B = 0$	-50			V
Emitter-base breakdown voltage	$V_{(BR)EBO}$	$I_E = -10\mu A, I_C = 0$	-5			V
Collector cut-off current	$I_{CBO}$	$V_{CB} = -50V, I_E = 0$			-0.1	$\mu A$
Collector cut-off current	$I_{CEO}$	$V_{CE} = -50V, I_B = 0$			-0.1	$\mu A$
Emitter cut-off current	$I_{EBO}$	$V_{EB} = -5V, I_C = 0$			-0.1	$\mu A$
DC current gain	$H_{FE(1)}$	$V_{CE} = -6V, I_C = -2mA$	130		400	
Collector-emitter saturation voltage	$V_{CE(sat)}$	$I_C = -100mA, I_B = -10mA$			-0.3	V
Base-emitter saturation voltage	$V_{BE(sat)}$	$I_C = -100mA, I_B = -10mA$			-1.1	V
Transition frequency	$f_T$	$V_{CE} = -10V, I_C = -1mA$ $f = 30MHz$	80			MHz

### CLASSIFICATION OF $H_{FE(1)}$

Rank	L	H
Range	130-200	200-400
MARKING	BA	