

SWITCHING AND PROTECTING



GRL



SWAN ELECTRIC

A MOBICON COMPANY



FUSES

RT18-32 / R015 SERIES



- 10 x 38mm
- 500VAC
- 2A TO 32A
- gG

RT18-63 / R016 SERIES



- 14 x 51mm
- 500VAC
- 2A TO 63A
- gG

RT18-125 / RT017 SERIES



- 22 x 58mm
- 500VAC
- 1A TO 125A
- gG

DNPV1038 SERIES



- 10 x 38mm
- 1000VDC / 500VAC
- 2A TO 30A
- gPV (Solar applications)

DNPV1085 SERIES



- 10 x 85mm
- 1500VDC / 690VAC
- 2A TO 25A
- gPV (Solar applications)

NH00 / RT16-00 SERIES



- 29 x 47 x 46mm
- 500VAC / 250VDC
- 2A TO 630A
- gG

NH1 / NT1 RT16-1 SERIES



- 46 x 46 x 66mm
- 500VAC / 250VDC
- 2A TO 630A
- gG

NH2 / NT2 RT16-2 SERIES



- 59 x 59 x 66mm
- 500VAC / 250VDC
- 2A TO 630A
- gG

NH3 / NT3 RT16-3 SERIES



- 68 x 68 x 66mm
- 500VAC / 250VDC
- 2A TO 630A
- gG

DNS20 -DNS51 / M1L SEMICONDUCTOR SERIES



- 20 x 66 TO 51 x 72mm
- 800VDC
- 35 TO 800A
- aR

FUSE BASES

DNF1-1 (DN56313)

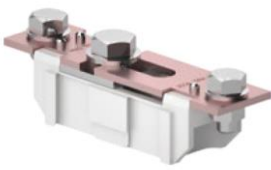

- SOLID LINK / NO FUSE
- DNF1-1 (DN56313) 250A
- DNF1-2 (DN56323) 400A
- DNF1-3 (DN56333) 630A

DNF1-1 (DN56310)



- FOR NH2 FUSES
- 250A
- 500VAC
- STACKABLE
- COVER AVAILABLE

DNF1-2



- FOR NH2 FUSES
- 400A
- 500VAC
- STACKABLE
- COVER AVAILABLE

DNF2-1 (DN56315)



- FOR NH FUSES
- 250A
- 500VAC
- STACKABLE
- COVER AVAILABLE

DNF1-3



- FOR NH3 FUSES
- 630A
- 500VAC
- STACKABLE
- COVER AVAILABLE

DNF2-3



- FOR NH3 FUSES
- 630A
- 500VAC
- STACKABLE
- COVER AVAILABLE

DNF COVER



- 1-POLES
- STACKABLE
- COVER ONLY (NO HOLDER / NO FUSE)

DNF COVER



- 3-POLES
- STACKABLE
- COVER ONLY (NO HOLDER / NO FUSE)

3-PHASE FUSE CARRIER DNF1 / DNF2



- 630A RATED
- 500VAC

CALL US FOR OTHER RELATED PRODUCTS



FUSE HOLDERS

RT18-32 (DN56110)



- FOR 10x38mm FUSE
- 32A 500VAC
- NO INDICATOR
- AVAILABLE IN 1P, 2P AND 3P

RT18-63 (DN56115)



- FOR 14x51mm FUSE
- 63A 500VAC
- NO INDICATOR
- AVAILABLE IN 1P, 2P AND 3P

RT18-125 (DN56120)



- FOR 22x58mm FUSE
- 125A 500VAC
- NO INDICATOR
- AVAILABLE IN 1P, 2P AND 3P

AVAILABLE IN 2P, 3P and 3P+N



RT18X-32 (DN56130)



- FOR 10x38mm FUSE
- 32A 500VAC
- LED INDICATOR
- AVAILABLE IN 1P, 2P AND 3P

RT18X-63 (DN56135)



- FOR 14x51mm FUSE
- 63A 500VAC
- LED INDICATOR
- AVAILABLE IN 1P, 2P AND 3P

RT18X-125 (DN56140)



- FOR 22x58mm FUSE
- 125A 500VAC
- LED INDICATOR
- AVAILABLE IN 1P, 2P AND 3P

DNPVF1-32L (DN53432)



- FOR 10x85mm FUSE
- 30A 1500VDC

OTHER COMBINATIONS AVAILABLE



ISOLATORS / DISCONNECTORS & TRANSFER / CHANGEOVER SWITCHES

ISOLATOR SWITCH - UKF



- 20A TO 63A
- 440VAC
- 2 TO 4-POLES
- ENCLOSED IP65

ISOLATOR SWITCH - HGL



- 63A TO 3150A
- 690VAC
- 3 OR 4-POLES
- EXTERNAL HANDLE OPTION

ISOLATOR SWITCH – DNH8(HGL)-63A



- 63A
- 690VAC
- 3 OR 4-POLES
- EXTERNAL HANDLE OPTION

ISOLATOR SWITCH – DNH8(HGL)-TM



- TRANSPARENT
- 400A TO 63A
- 3 OR 4-POLES
- EXTERNAL HANDLE OPTION

ISOLATOR HANDLE

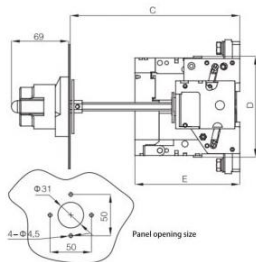

- DOOR MOUNT

DC ISOLATOR – DNH19



- 100A TO 1250A
- 1000VDC / 1500VDC
- 2 TO 4-POLES (BRIDGING OPTION)
- EXTERNAL HANDLE OPTION

MANUAL CHANGEOVER SWITCH – DNQ7



- 63A TO 125A
- 230VAC / 400VAC
- 1 TO 4-POLES
- DIN RAIL MOUNT

MANUAL CHANGEOVER SWITCH - HGLZ



- 63A TO 3150A
- 400VAC
- 3 OR 4-POLES
- EXTERNAL HANDLE OPTION

MOTORISED CHANGEOVER SWITCH – DN2R-100



- 16A TO 100A
- 400VAC
- 2 TO 4-POLES
- 220VAC MOTOR

MOTORISED CHANGEOVER SWITCH – DNQ8



- 16A TO 3200A
- 500 – 800VAC
- 3 OR 4-POLES
- 220VAC MOTOR

FUSED ISOLATORS / DISCONNECTORS

FUSED ISOLATOR – DNH1-2P (DN31...)



- 2-POLES
- 160A AND 250A
- 400VAC
- FOR NH1 FUSES

FUSED ISOLATOR – DNH1-3P (DN310..)



- 3-POLES
- 160A / 250A / 400A / 630A / 800A
- 380VAC
- FOR NH1 FUSES

VERTICAL FUSED ISOLATORS – DNH18



- 160A / 250A / 400A / 630A
- 400VAC
- SYNCHRONOUS OR INDEPENDENT OPERATION

FUSE LINKS



PV System | Fuse | LBS | Busbar System
30+ Years Factory Manufacturing Experience

www.grlgroup.com

SURGE PROTECTORS

SURGE PROTECTORS – SPD AC/DC SERIES



- AVAILABLE IN : 1P, 2P, 3P, 4P 1P+N AND 3P+N
- 275VAC - 550VAC AND 350VDC – 750VDC
- 10 – 80KA (8/20uS)

SURGE PROTECTORS – SUP / DN4H-S PV SERIES



- AVAILABLE IN : 1P, 2P, 3P
- 500VDC / 600VDC / 800VDC / 1000VDC / 1200VDC / 1500VDC
- 20KA / 40KA / 60KA

INDEX	
CONTENTS	PAGE
BASES FOR FUSES	H3
CHANGE OVER SWITCHES	H5
FUSE BASES	H3
FUSE HOLDERS	H4
FUSED ISOLATORS	H6
FUSES	H2
HOLDERS FOR FUSES	H4
ISOLATOR SWITCH	H5
ISOLATORS FUSED	H6
ISOLATORS FUSED VERTICAL	H6
PROTECTORS SURGE	H6
PV FUSES	H2
SURGE PROTECTORS	H6
SWITCHES CHANGE OVER	H5
VERTICAL FUSED ISOLATORS	H6

WE DO NOT HAVE A MINIMUM ORDER QTY OR VALUE

WE DELIVER TO ANY LOCATION, AT ORDINARY COURIER FEES

IF WE DO NOT HAVE IT... WE WILL SOURCE IT FOR YOU



[OUR LATEST CATALOGUE](#)



www.swan-electric.co.za

CITY	TEL	EMAIL
CAPE TOWN	+27 21 555 0644	sales@swan-electric.co.za
DURBAN	+27 31 206 2783	
JOHANNESBURG	+27 11 493 9307	
MIDRAND	+27 11 314 0202	
PORT ELIZABETH	+27 41 364 1893	

SWAN ELECTRIC IS A MOBICON COMPANY